

# OS & Y Type Casting Bellows Valve

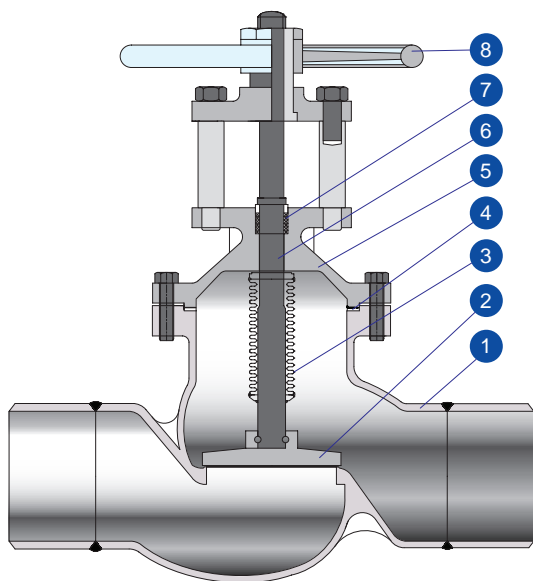

Catalog No. U-VCBC  
JAN. 2013



## Materials of Construction

No.	Description	Materials
1	Body	SCS 19
2	Disk	PTFE
3	Bellows	316L SS
4	Gasket	TEFLON
5	Bonnet	SCS 19
6	Stem	304L SS
7	Packing	TEFLON
8	Handle	FCD 450

## Specification

Size	64A	80A	100A	125A	150A	200A	250A	300A	350A	400A	450A	500A
Orifice Size	65	80	100	124	148	200	250	300	350	400	440	490
Cv Value	81	132	200	302	434	772	1200	1600	2000	2650	3100	3400
Max. Working Pressure	10 kgf/cm <sup>2</sup>											
Max. Working Temperature	-10 ~ 80°C											
Internal Leakage Allowance - He (Holding Time - Min 30 sec)	≤ 1x10 <sup>-6</sup> atm.cc/s											
External Leakage Allowance - He (Holding Time - Min 1 min)	≤ 1x10 <sup>-6</sup> atm.cc/s											

## Internal Surface Finish Levels

Grade		BA	EP
Surface Roughness	Average	< 0.4 μm	< 0.125 μm
	Maximum	< 1.6 μm	< 0.4 μm
Cleaning		Degreasing + Precision Cleaning	
Clean Room Environment		Class 10 (Some Products, Class 100)	

## How To Order



Uni-Lok Valve

Valve Type

Connection Type

Connection Size

Material

Surface Finish Level

Valve Type	
BC	Bellows Valve for Low Pressure (CASTING TYPE)

Connection Type	
WB-*A	Butt Weld-Pipe
FL	Flanged

Connection Size						
Pipe Size Designator						
Pipe Size	65A	80A	100A	125A	~	450A
Designator	65A	80A	100A	125A	~	450A

Materials	
S4	304 SS/SCS 13
SS	316 SS/SCS 14
SL	316L SS/SCS 16

Surface Finish Level	
AP	Annealing & Pickling
BA	Bright Annealing
EP	Electro Polishing

## Ordering Information & Dimensions

Model	End Connections	SIZE	Dimensions (mm)		
			L	H	D
	Butt Weld	65A	416	280	160
		80A	441	300	200
		100A	492	380	
		125A	556	470	300
		150A	606		
		200A	795	700	400
		250A	1022	900	450
		300A	1100	1000	500
		350A	1187	1050	710
		400A	1314		
		450A	1200	1150	800
	Flange	65A	216	280	160
		80A	241	300	200
		100A	292	380	
		125A	356	470	300
		150A	406		
		200A	495	700	400
		250A	622	900	450
		300A	698	1000	500
		350A	787	1050	710
		400A	914		
		450A	1040	1150	800

Dimensions are for reference only and are subject to change without prior notice.



CONNECTS THE WORLD SINCE 1984 [www.unilok.com](http://www.unilok.com)

**본사 및 제1공장**  
 인천광역시 남동구 고잔동 725-13번지  
 남동공단 152블럭 12롯데 ☎ 405-822  
 전화 : 032-822-6600  
 팩스 : 032-822-6604

**제2공장**  
 인천광역시 남동구 고잔동 684-7번지  
 남동공단 114블럭 8롯데 ☎ 405-818  
 전화 : 032-433-6601  
 팩스 : 032-441-7600

**Headquarters & 1<sup>st</sup> Factory**  
 152 Block-12 Lot, Namdong Indus-Park, 725-13,  
 Gojan-Dong, Namdong-Gu, Incheon, Korea  
 Tel : +82-32-821-6673  
 Fax : +82-32-822-6604

**2<sup>nd</sup> Factory**  
 114 Block-8 Lot, Namdong Indus-Park, 684-7,  
 Gojan-Dong, Namdong-Gu, Incheon, Korea  
 Tel : +82-32-433-6601  
 Fax : +82-32-441-7600